



- optical 3D sensor
- measuring principle
- scanning device
- high speed camera
- point evaluation
- SDK
- evaluation algorithms
- optional evaluation algorithms
- optional profile averaging
- scanning increments
- stative
- system software
- evaluation software
- simplified automation
- optional software modules

specification

high performance sensor with motorized objective turret for up to 4 objectives

coherence scanning (white-light) interferometer

piezo positioning system / close loop capacity gauge control

200  $\mu\text{m}$  scanning range / 30 nm linearity

1280 x 1024 pixel / 935 fps and acceleration up to 10 kfps with decimation

massive parallel in real time on the GPGUs

(general purpose graphic processing unit / programmable high performance graphic boards)

software libraries in C++ and C# with sample application and source code

control of all sensor functions

VSI (vertical scanning interferometry). EPSI (extended phase shift interferometry)

HD-EPSI (high density – extended phase shift interferometry) with small scanning increments

automated averaging over up to 40 single scans for noise reduction

variable optimization between speed and resolution

optional system components

manual and motorized positioning axis. granite portals and tip tilt compensations

smartVIS3D – user interface for measurements

MountainsMap® - stitching. visualization and evaluation of 3D point clouds

IO module for the start of predefined measuring and evaluation processes

smartSTITCH – with heigh and angle compensation / optimized stitching of nano structures

smartLAYER – evaluation of coating thickness



# smart WLI system performance and configuration

increment	17 nm*	67 nm	201 nm
scanning speed full resolution	16 $\mu\text{m/s}$	65 $\mu\text{m/s}$	206 $\mu\text{m/s}$
repeatability RMS**	0.005 nm	0.01 nm	0.02 nm
topography reproducibility***	0.05 nm	0.1 nm	0.2 nm
1- $\sigma$ repeatability 245 nm step height	0.3 nm	0.2 nm	0.15 nm
1- $\sigma$ repeatability 20 $\mu\text{m}$ step height	10 nm	7 nm	5 nm
1- $\sigma$ repeatability 100 $\mu\text{m}$ step height	20 nm	15 nm	10 nm

\* requires optional HD-EPSI

\*\* 1- $\sigma$  repeatability  $S_q$  / single scan. without phase or profile averaging. laboratory conditions. 1 million points after 3x3 denoising filter

\*\*\*  $S_q/\sqrt{2}$  – profile difference of 2 scans. single scan. without profile averaging. laboratory conditions. 1 million points after 3x3 denoising filter

	standard objectives 2D localization				interference objectives for 3D measurements			
available objectives	2.5x	5x	5x	10x	20x	50x	100x	115x**
aperture	0.075	0.13	0.13	0.3	0.4	0.55	0.7	0.8
working distance / mm	8.8	22.5	9.3	7.4	4.7	3.4	2	0.7
measuring area / mm <sup>2</sup>	6.7 x 5.4	3.4 x 2.7	3.4 x 2.7	1.6 x 1.4	0.83 x 0.68	0.34 x 0.27	0.16 x 0.14	0.15 x 0.12
sampling interval / $\mu\text{m}$	5.2	2.6	2.6	1.3	0.65	0.26	0.13	0.11
optical resolution / Rayleigh criterion	4.23	2.44	2.44	1.06	0.79	0.58	0.45	0.4
optical resolution / Sparrow criterion	3.26	1.9	1.9	0.81	0.61	0.44	0.35	0.31



# smartWLI acceleration using decimation and ROI

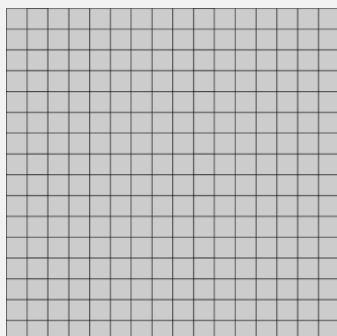

partial area out of 1280 x 1024 pixel

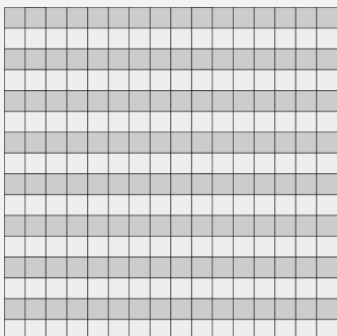

active pixel – decimation 2

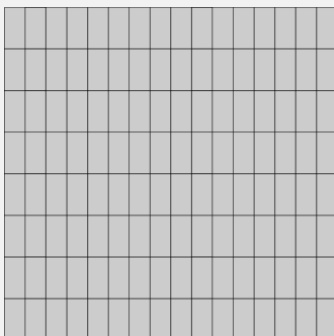

result: 1280 x 512 pixel

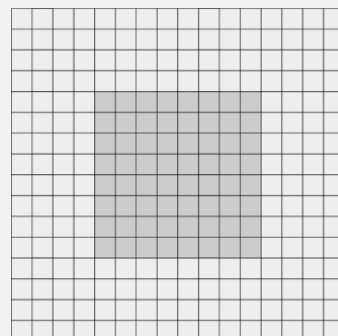

active pixel

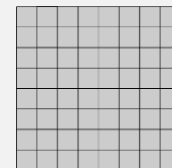

result

step height*	scanning speed** - $\mu\text{m/s}$					
	17 nm	70 nm	200 nm	600 nm	1000 nm	
1280 x 1024 / full resolution	16	65	206	618	1030	
1280 x 512 / decimation 2	32	131	411	1233	2055	
1280 x 256 decimation 4	64	262	823	2469	4115	
1280 x 128 decimation 8	127	524	1646	4938	8230	
1280 x 86 decimation 12	191	785	2468	7404	-	
800 x 600 AOI	31	127	363	1089	1815	
640 x 480 AOI	38	158	452	1356	2260	
400 x 300 AOI	61	252	720	2160	3600	

\*selection of possible step heights

\*\*faster scanning speed cause a higher noise levels



# smartWLI sensor dimensions and connections

## sensor dimensions

height	271.7 mm
width	212.4 mm
depth	134 mm
weight*	5.5 kg

## connectivity - cables

cable length	3 m (optional up to 7 m)
camera	10 GigE
piezo	special connector
power supply	HR-10A-7P-6s
trigger	HR25-7TP-8S
power consumption	3 – 7 W
LED	up to 4 W
spectrum	green / $\lambda \approx 520 \text{ nm}$

\* without objective and cables

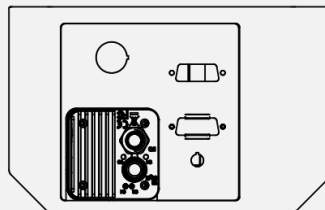
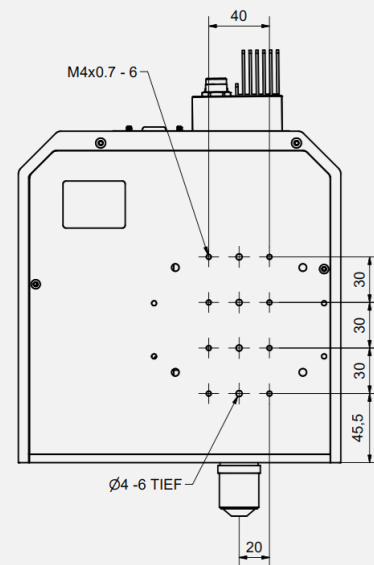
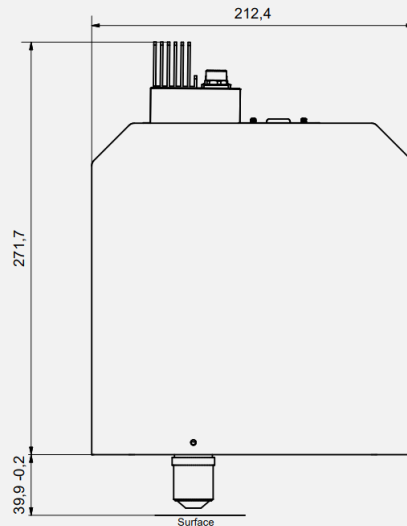



**controller**

**key features**

housing	industrial 19" rack / 6 height units
power supply	100 – 240 V AC / 50-60 Hz
LED	LED controller
piezo	piezo control unit
stages	optional controller for motorized xyz stages

**standard PC**

operating system	Windows 10/11
CPU	Core i9
RAM	64 GB
SSD	1 TB

**GPGPU**

**optional high end GPGPU**

FP 32 (float)	16 TFLOPS	82 TFLOPS
memory	12 GB / GDDR6	24 GB / GDDR6

**optional components**

27" monitor, keyboard, mouse

**environmental conditions**

humidity	up to 80% / non-condensing
operation temperature	10 - 35 °C

## controller dimensions

height	286 mm
width	520 mm
depth	430.9 mm
weight	app. 25 kg

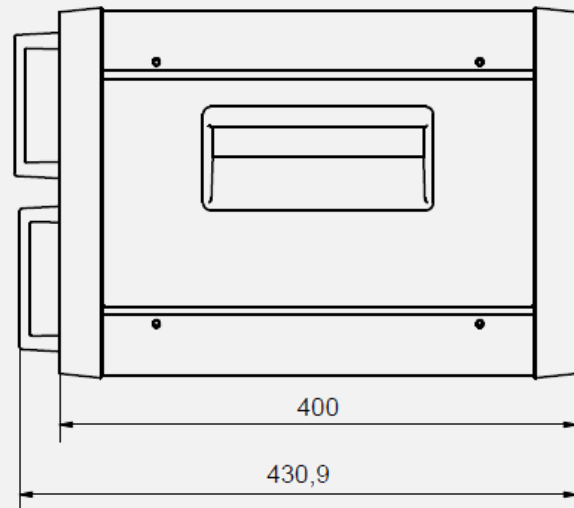
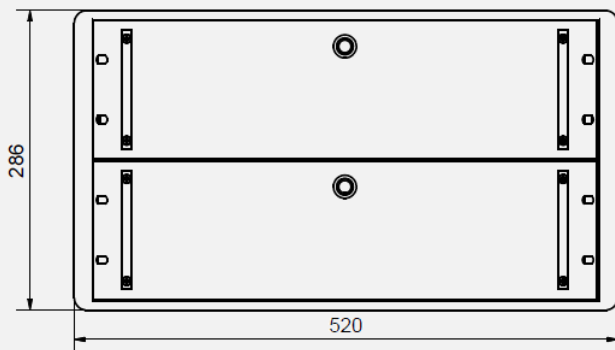
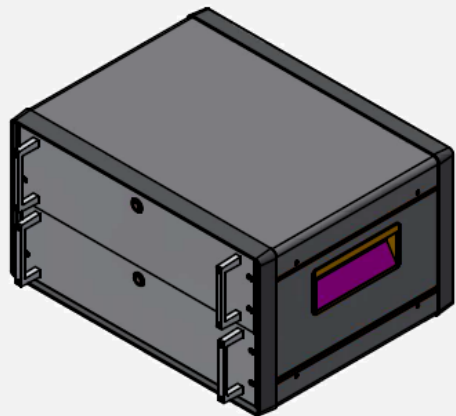

modification date November 9, 2023

disclaimer changes are subject to technical progress